

cifre
cerámica

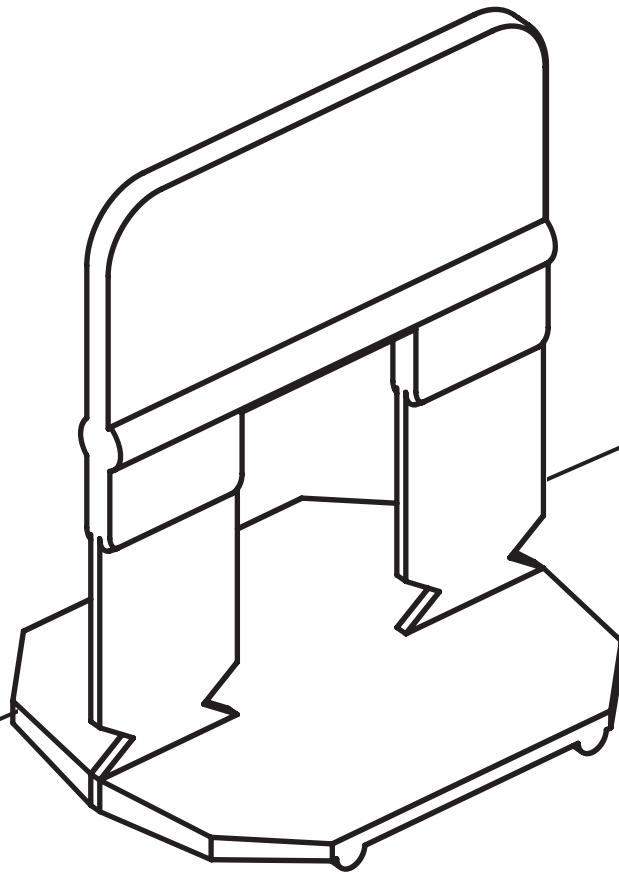

levelling
SYSTEM

FLATNESS BETWEEN TILES



LEVELLING SYSTEM

Levelling system ensures flatness between tiles avoiding movements during the mortar setting.

This reduces the time for the ceramic laying obtaining a perfect lippage-free finish.

A fast and 100% effective tool.



Reduces laying time.



Ensures flatness between tiles.





Minimum joint less than 0,5 mm.
Available for 0,5 - 1 - 1,5 - 2 and 3 mm.

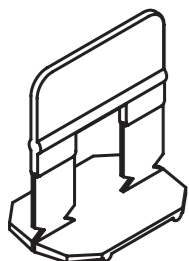

Range of use: from 3 to 30 mm.



ADVANTAGES

-  Levelling system Cifre Ceramics indispensable for rectified ceramics, porcelain tiling and large formats.
-  They are the only solution to avoid steps between ceramic pieces..
-  Allows for high quality finishes, saving time.

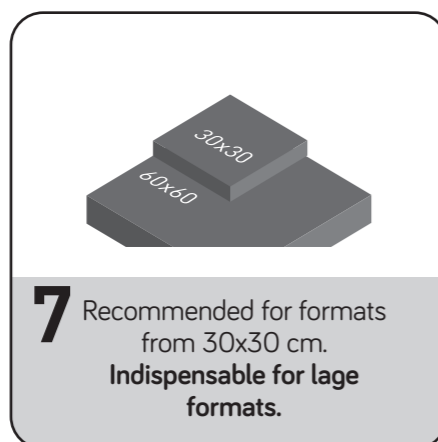
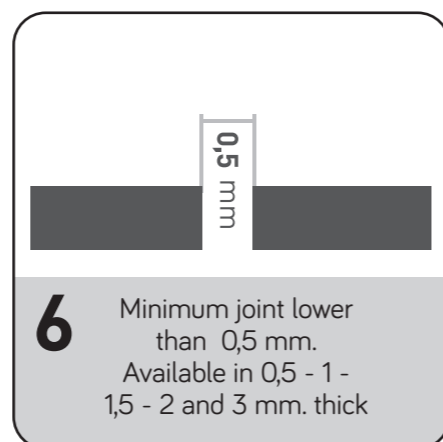
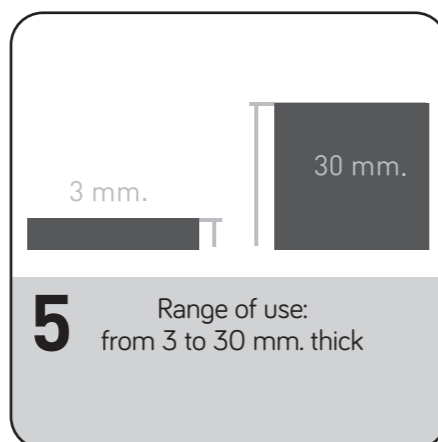
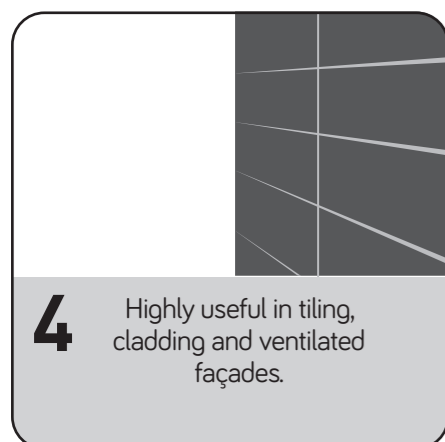
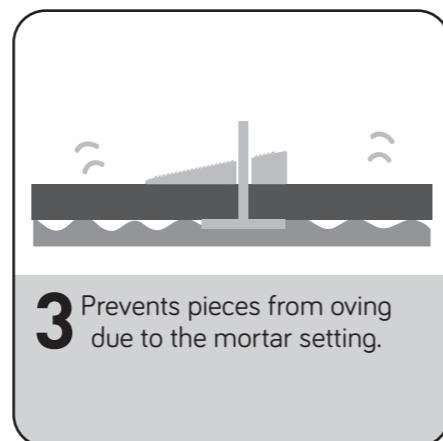
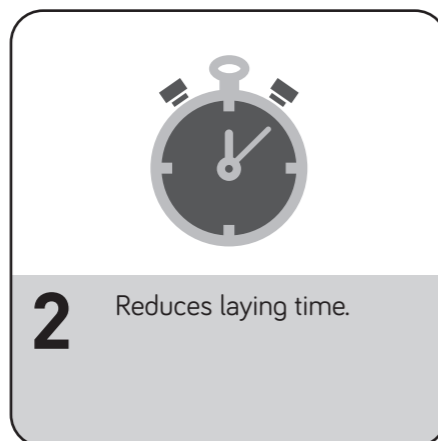
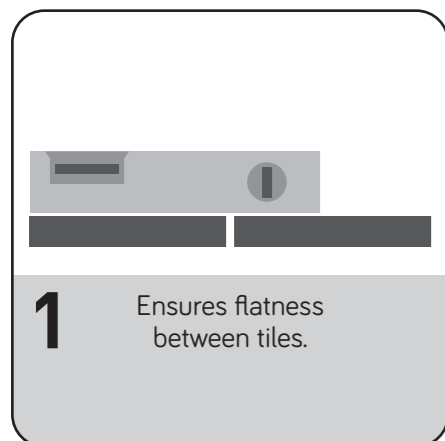

SYSTEM COMPONENTS



1 | Clipso

Clips are made of high quality material, which allows clips to be highly resistant to traction so that heavy pieces can be adjusted fast and effectively. Clips have side cuts (patented), which allow us to remove them easily, just with a knock on the side in the joint direction, when the work is finished (mortar setting)..



2 | Wedges

Wedges have saw-shaped teeth to be adjusted to the crosshead precisely and achieve top efficiency. The wedge base is round not to damage ceramics. Wedges can be reused.



3 | Pliers Ceramic

The main characteristic is its scale bar for the floor tile thickness (patented system). The scale bar allows us to adjust the tool to the pressure needed easily, quickly and effectively.



4 | Kit Ceramic

Kit de 100 Calzos: Particularly designed to start using leveling systems.

Consists : 100 crossheads, 100 wedges and pliers.

STEPS TO FOLLOW



levelling SYSTEM

QR CODE



VIDEO CIFRE CERAMIC
LEVELLING SYSTEM.

Read the qr and it will show
you our video explaining the
levelling system.

For perfect installation finished
we recommend our
levelling system.

We will not accept any complaint if
the material has not been installed
with our levelling system or a
similar one.

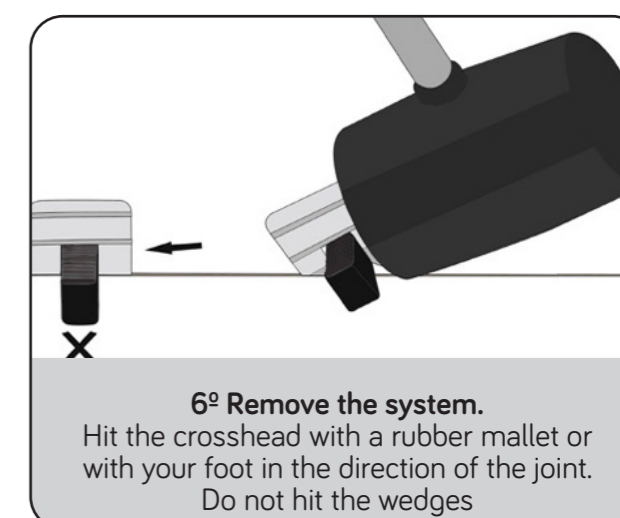
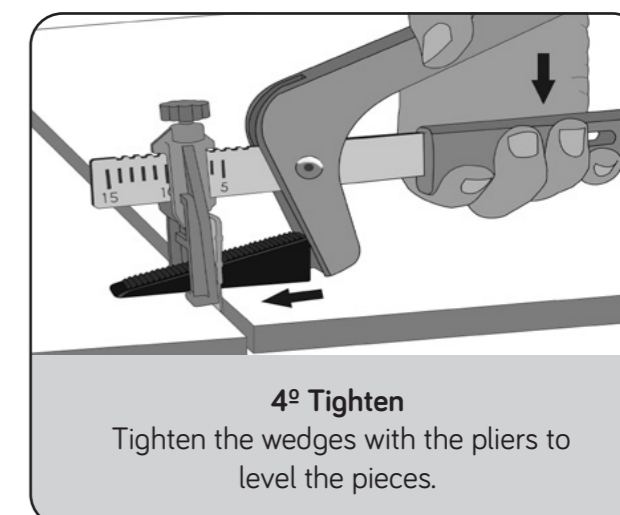
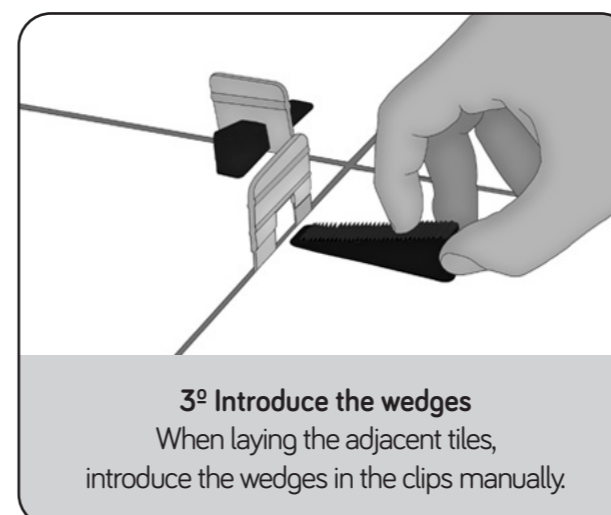
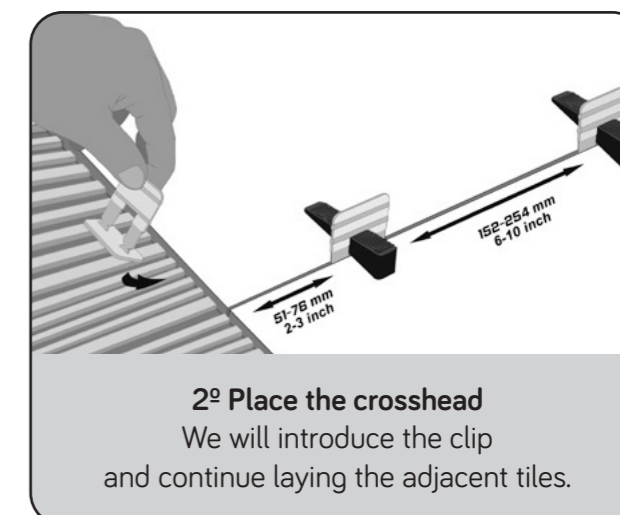
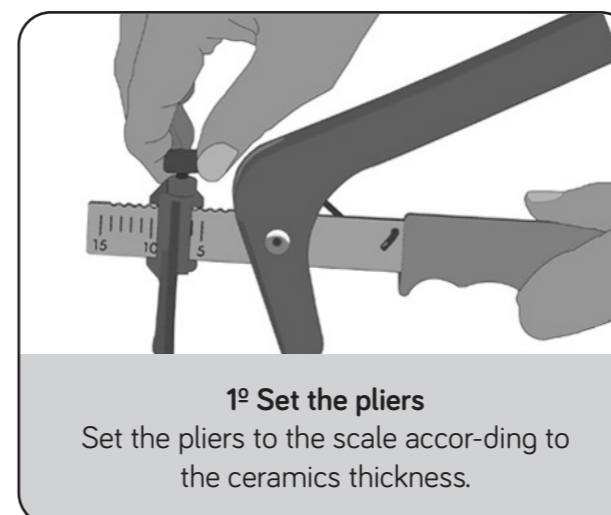
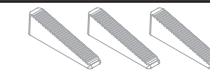



levelling
SYSTEM

TECHNICAL
INFORMATION

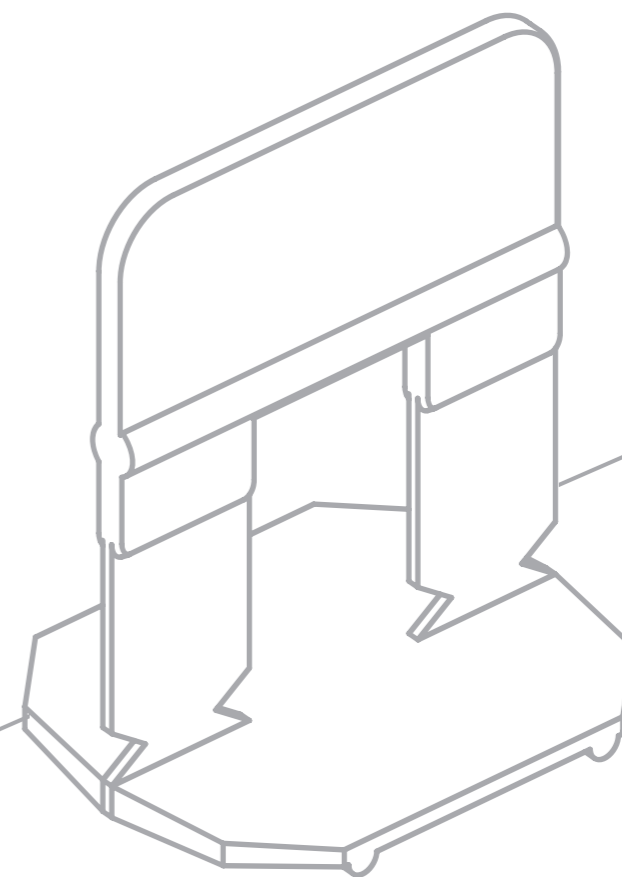

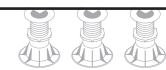

CLIPS

SP 2059

CLIPS FOR CERAMIC

Model : Clips Levelling System

It is used to adjust heavy parts quickly and effectively.

It is available in different sizes, depending on the desired thickness.

COMPOSITION

Polyamide

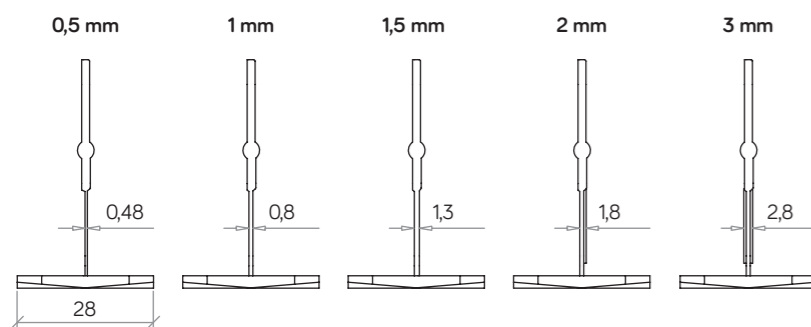
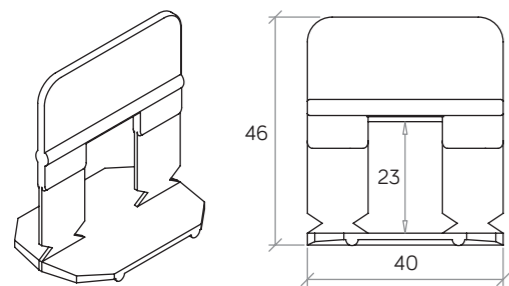

WEDGES

SP 2043

WEDGES FOR CERAMIC

Model : Wedges Levelling System

The wedge is adjusted in the chock with our Levelling System Pliers.

Its base is completely rounded, which prevents the porcelain from being damaged when the system is removed.

COMPOSITION

Polyamide
Fiber

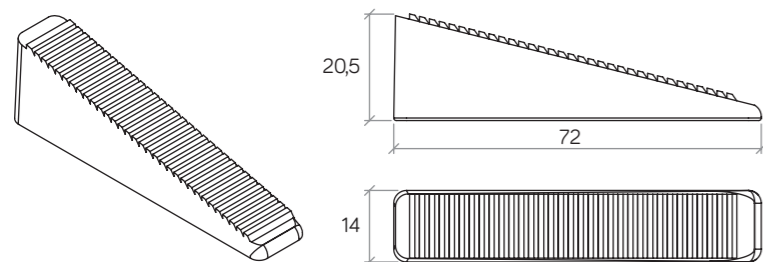

PLIER CERAMIC

SP 2057

WEDGE ADJUSTMENT PLIERS

Model : Plier Ceramic

It is used for thicknesses between 3 and 15 mm. in ceramics.

* Wedge-base is required for thickness between 3 and 5 mm.

The parts in contact with the tile are made of plastic to avoid damages..

COMPOSITION

Polyamide
Fiber
Stainless steel

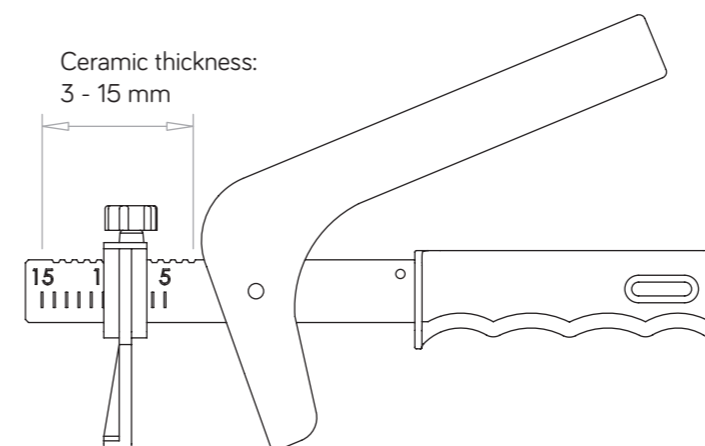
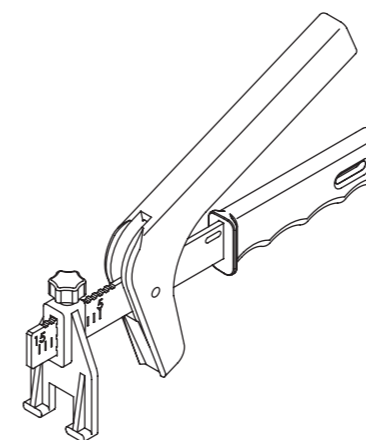



El contenido de este catálogo está protegido por la ley de Propiedad Intelectual, Real Decreto Legislativo 1/1996. Cualquier reproducción del mismo, en parte o en su totalidad, sin autorización expresa de CIFRE CERAMICA, SL. puede ser sancionada conforme el código penal.

CIFRE CERÁMICA SL., se reserva el derecho de modificar y/o suprimir ciertos modelos, características o presentaciones de los modelos expuestos en este catálogo, sin previo aviso, por exigencias de producción sin que se contraiga derecho o perjuicio alguno.

Todas nuestras medidas estándar estan sujetas a posibles variaciones por circunstancias de la producción.

Los ambientes que se muestran en este catálogo, son sugerencias decorativas de carácter publicitario.

Los colores y/o tonos de las piezas, pueden presentar ligeras diferencias respecto a las piezas reales. Es importante antes de la colocación comprobar que las piezas corresponden a los modelos y características de calidad, tono y calibre solicitados.

Debiéndose utilizar en la instalación real las instrucciones de colocación editadas por CIFRE CERAMICA.SL.



The content of this catalogue is protected by the Intellectual Property law, Royal Decree Legislative 1/1996. Any reproduction in part or in its entirety, without express authorisation of CIFRE CERAMICA, SL, can be punishable under the penal code.

Due to production constraints, CIFRE CERÁMICA SL. reserves the right, without prejudice, to modify and/or discontinue certain products or features, or vary the appearance of products in this catalogue, without prior notice. Statutory rights are not affected.

All standard measurements are subject to possible variation due to the production process.

The illustrations shown in this catalogue are representative only and for advertising purposes.

The colours and/or shades of items shown may differ slightly from the actual items. Before installation we strongly recommend you ensure all items delivered are as required in terms of product, quality, colour and calibre.

CIFRE CERAMICA.SL fixing instructions must be followed at all times.



Le contenu de ce catalogue est protégé par la loi de propriété intellectuelle, royal décret législatif 1/ 1996. La reproduction d'une part ou de la totalité sans autorisation de CIFRE CERAMICA peut être sanctionné par le code penal.

CIFRE CERÁMICA SL., se réserve le droit de modifier et/ou de supprimer certains modèles, caractéristiques ou présentations des modèles de ce catalogue, sans préavis, pour des raisons de production, sans contracter aucun droit ou dommage.

Toutes les mesures standard peuvent faire l'objet d'éventuelles variations en raison des circonstances de production.

Les ambiances faisant partie de ce catalogue sont des propositions de décoration de type publicitaire.

Les couleurs et/ou les tons des pièces peuvent présenter de légères différences par rapport aux pièces réelles. Il est important de vérifier avant la pose que les pièces correspondent aux modèles et aux caractéristiques concernant la qualité, le ton et le calibre sollicités par le client.

Lors de la pose, les instructions de pose publiées par CIFRE CERAMICA SL. doivent être respectées.



ES07/3348

CIFRE GROUP™

Ctra. Vila-real - Onda, km 10
12200 Onda - Castellón SPAIN

Tel.: +34 964 506 969

Fax: + 34 964 521 593

www.cifreceramica.com

e-mail: cifre@cifreceramica.com

VERSION V3 - SEPTEMBER 2020